

RABUGGI exhaust piping plan - (Ref. also: Layout drawing)

scale: 1 / 10

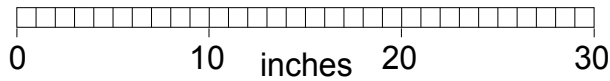

06-14-07 R.A.B.
updated 10-21-23 R.A.B.

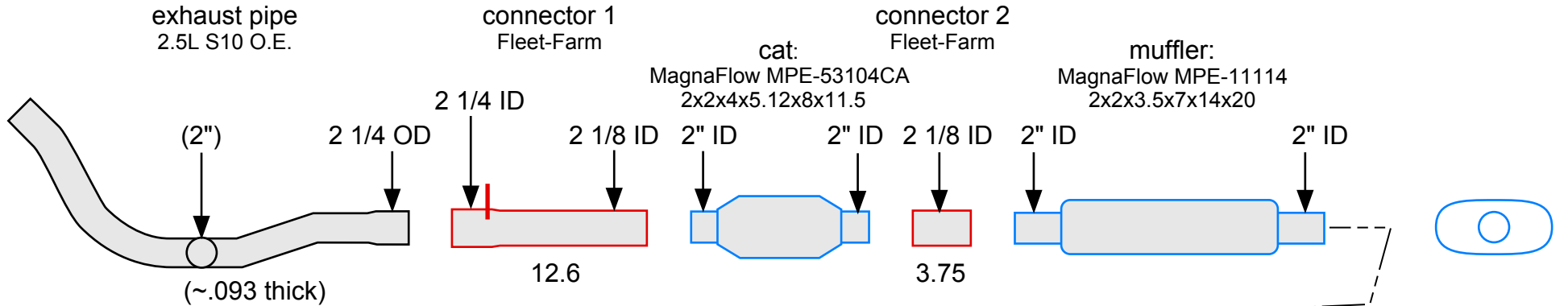

- (4) 2 1/8 clamps
- (1) 2 1/4 clamp
- (2) hangers
- high temp paint

Ref. '91 2.5L I-4
2.0 in. dia. = 3.14 sq.in.

5 tailpipe set - ○○○○○
1" EMT conduit (1.049 ID, .057 wall, 1.17 OD)
5 x 1.049 in. dia. = 5 x .864 sq.in. = 4.32 sq.in.

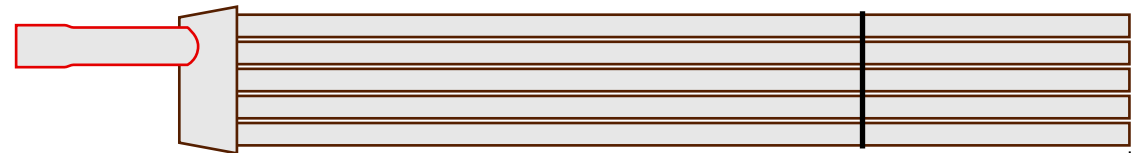

Ref:
downpipe 1:1 Dwg.

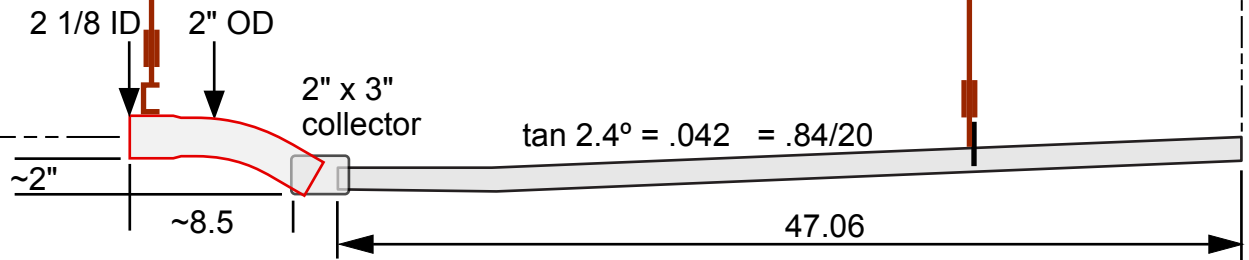

Weights 08-06-07: header pipe, connector 1 & weld tab, cat., muffler, 5 clamps, 2 hangers: 20 lb.
collector pipe, collector, 5 t'pipes & weld tab, bolts: 18 lb.
total: 38 lb.